

M-TYPE CARBIDE DRILL BITS

For Dowel and Through-hole Drilling

KANEFUSA



Kanefusa - A New Dimension of Performance



JQA-QM3710



JQA-EM3137
Head Office
Factory

*Specifications and appearance are subject to change without notice.
Photographs and illustrations may vary from actual products.

0-18-8
[Class] [Article] [Revision]

Features and Reliable Performances

KANEFUSA M-type carbide drill bits for dowel and through-hole drilling enable outstanding sharp cut and unprecedented long cutting life. Best for particleboard, MDF, plywood and other hard-to-cut materials as well as solid wood.

M-Type bits for dowel drilling

The large scoring edge ① ensures incomparably sharp and durable boring. Sharpening on the grooved area ③ reproduces sharpness of scoring edges and plunging edges ②. Thinning on the area ④ furthermore makes lighter cutting.

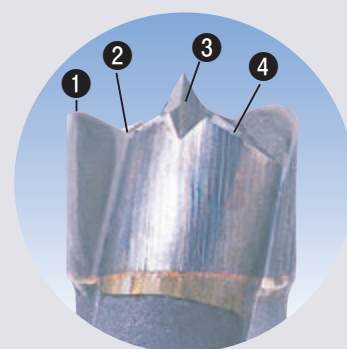

M-Type bits for through-hole drilling

For through-hole drilling, M-type bits have a plunging point and finishing edges, which ensure high quality boring without causing chipping even for overlaid products with a hard material like melamine.



Accessories

SIDE-LOCK HOLDER for easy and quick tool change.

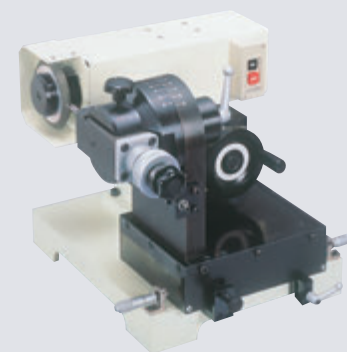
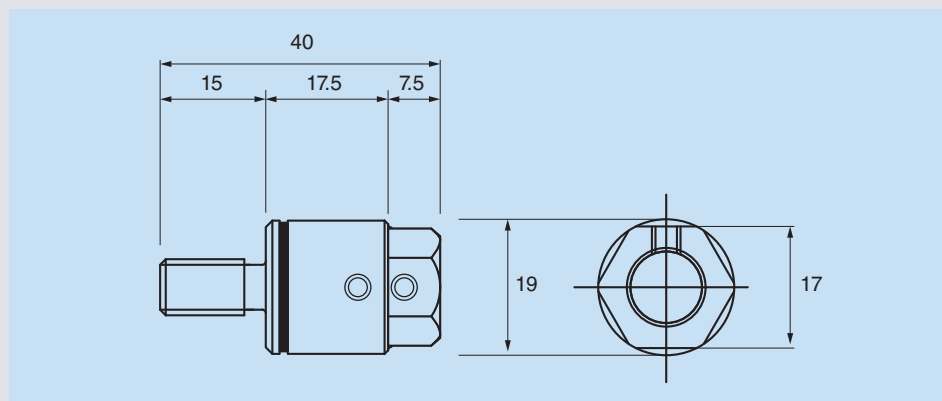

DABOKEN is a special sharpening machine developed by Kanefusa for an ideal resharpening.

Product Lineup

M-type bits for dowel drilling

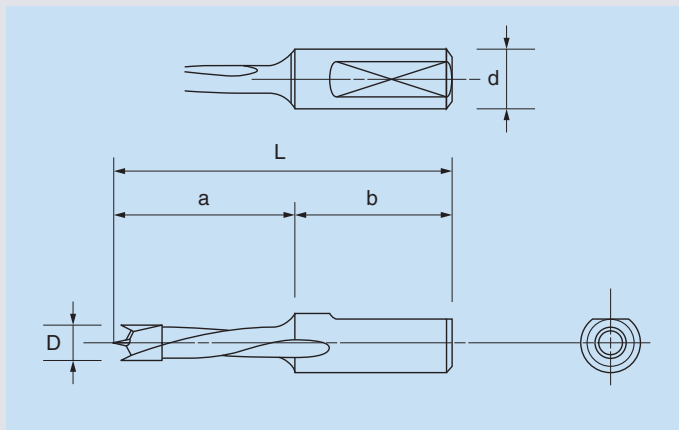

	Size [mm]				
	D	d	L	a	b
1	5	10	57.5	30.5	27
2	6	10	57.5	30.5	27
3	8	10	57.5	30.5	27
4	10	10	57.5	37.5	20
5	5	10	70.0	40	30
6	6	10	70.0	40	30
7	8	10	70.0	40	30
8	10	10	70.0	40	30

Other Specifications are available upon request.
Products for right and left rotation are available.

M-type bits for through-hole drilling

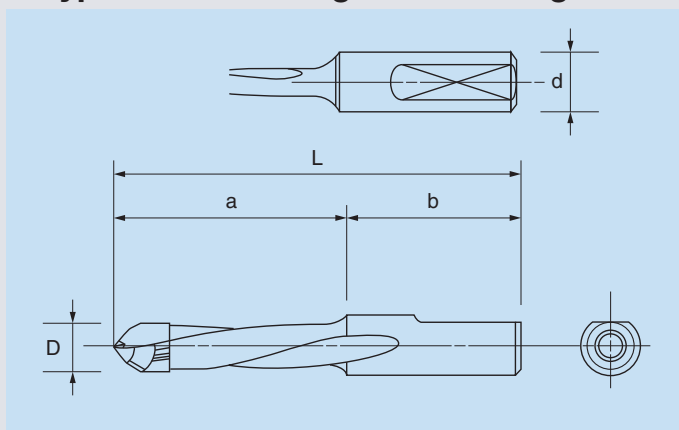

	Size [mm]				
	D	d	L	a	b
1	5	10	57.5	32.5	25
2	6	10	57.5	32.5	25
3	8	10	57.5	32.5	25
4	10	10	57.5	32.5	25
5	5	10	70.0	40	30
6	6	10	70.0	40	30
7	8	10	70.0	40	30
8	10	10	70.0	40	30

Other Specifications are available upon request.
Products for right and left rotation are available.



<http://www.kanefusa.net>

KANEFUSA CORPORATION

Head Office / Factory

1-1 Nakaoguchi, Ohguchi-cho, Niwa-Gun
Aichi-ken, Japan, Postal Code 480-0192
Tel : +81 587 95 7221
Fax : +81 587 95 7226
E-mail: sales-ex@kanefusa.co.jp

PT. KANEFUSA INDONESIA

EJIP Industrial Park, Plot 8D, Cikarang Selatan,
Bekasi 17550, West Java, Indonesia
Tel : +62 21 897 0360
Fax: +62 21 897 0286
+62 21 897 0287
E-mail : sales@kanefusa.co.id

Surabaya Service Center

Jl. Berbek Industri VII/5B Kepuhkiriman, Waru Sidoarjo 61256
Tel : +62 31 849 1784
Fax: +62 31 849 2784
E-mail : ssc@kanefusa.co.id

KANEFUSA EUROPE B.V.

De Witbogt 12, 5652 AG, Eindhoven, The Netherlands
Tel : +31 40 2900901
Fax: +31 40 2900908
E-mail : info@kanefusa.nl

KANEFUSA USA, INC.

621 Dolwick Drive, Erlanger, KY 41018, USA
Tel : +1 859 283 1450
Fax: +1 859 283 5256
E-mail : sales@kanefusa-na.com

KANEFUSA CHINA CORPORATION

NO.50 Zhuzhu Road, Lujia Town Kunshan city, Jiangsu, China
Tel : +86 512 57875072
Fax: +86 512 57875073
E-mail : yy@kanefusa-cn.com

Tianjin Office

Sanjinglu No.5 Dongli economic development zone Tianjin city CHINA
Tel : +86 22 5823 7633
Fax: +86 22 5823 7632
E-mail : tjkc03@kanefusa-cn.com

Guangdong Office

No.2 Danhen Road, Danzao Town Foshan City, Guangdong, China
Tel : +81(0)75785406562
Fax: +81(0)75785406571
E-mail : fssales@kanefusa-cn.com

KANEFUSA INDIA PRIVATE LIMITED

Plot No.232, Sector-8, IMT Manesar, Gurgaon,
Haryana PIN 122-050 India
Tel : +91 124 420 8440
Fax: +91 124 420 8441
E-mail : info@kanefusa.co.in

KANEFUSA DO BRASIL LTDA.

Rua Bom Pastor, 2732 Bloco Torre Sul - Sala 73
São Paulo - SP Cep:04203-003
Tel : +55 11 2372 7664
Fax: +55 11 2372 7663
E-mail : vendas@kanefusa.net.br

KANEFUSA MEXICO S.A. DE C.V.

Brecha A Mezquite KM 0+193, Carretera 45 Leon-Silao KM 156+400
Bodega 27 Col. Nuevo Mexico C.P. 36270 Silao, Gto.
Tel : +52 472 748 6314
Fax: +52 472 748 6313
E-mail : info@kanefusa.com.mx



古紙パルプ配合率80%
再生紙を使用しています。